

Tree Diagram

What The Tree Diagram is used to systematically map out, in increasing detail, the full range of tasks that need to be accomplished in order to achieve the primary goal. It provides us with the methods by which we achieve our purpose.

When Use the Tree Diagram when a goal has been assigned but it isn't a simple assignable job, when the implementation will be complex, or there are strong consequences for missing key tasks.

- How**
1. **Develop the goal statement:** You must start with an overall goal which is systematically broken down into the methods by which it will be achieved. The goal statement can come from an Affinity Diagram, Interrelationship Digraph, and Brainstorming.
 2. **Assemble the right team:** The Tree is action planning, requiring specialized knowledge from people familiar with implementation issues.
 3. **Generate the major headings:** Ask the question; What needs to happen, or be addressed, to resolve, or achieve, the problem, or goal?
 4. **Complete each major path:** Select one major path to complete. Work back along each limb until all tasks to accomplish the goal are addressed.
 5. **Review completed diagram for logical flow:** Logical flow means that accomplishing two limbs will accomplish the higher branch goal.

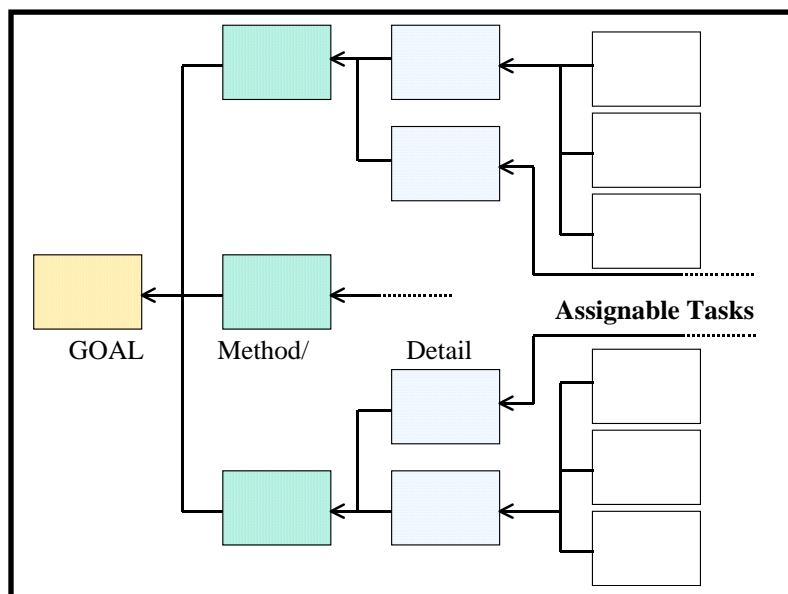

[MORE INFO!](#)

See pages 73 to 96 in the Memory Jogger Plus +.